

## can you install remote starter manual transmission

---



**File Name:** can you install remote starter manual transmission.pdf

**Size:** 4823 KB

**Type:** PDF, ePub, eBook

**Category:** Book

**Uploaded:** 4 May 2019, 19:33 PM

**Rating:** 4.6/5 from 591 votes.

**Status:** AVAILABLE

Last checked: 1 Minutes ago!

**In order to read or download can you install remote starter manual transmission ebook, you need to create a FREE account.**

[\*\*Download Now!\*\*](#)

eBook includes PDF, ePub and Kindle version

[Register a free 1 month Trial Account.](#)

[Download as many books as you like \(Personal use\)](#)

[Cancel the membership at any time if not satisfied.](#)

[Join Over 80000 Happy Readers](#)

### Book Descriptions:

We have made it easy for you to find a PDF Ebooks without any digging. And by having access to our ebooks online or by storing it on your computer, you have convenient answers with can you install remote starter manual transmission . To get started finding can you install remote starter manual transmission , you are right to find our website which has a comprehensive collection of manuals listed.

Our library is the biggest of these that have literally hundreds of thousands of different products represented.



## Book Descriptions:

# can you install remote starter manual transmission

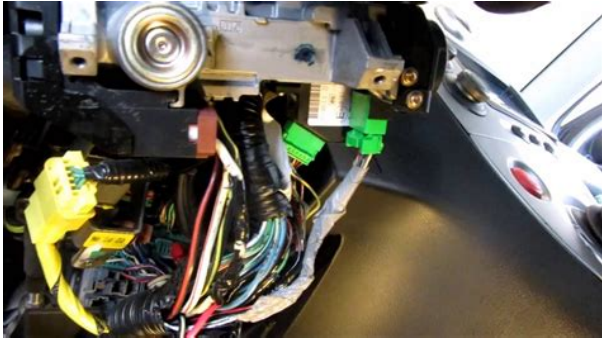

He also ghostwrites articles for numerous major trade publications. Without that, a remote starter could engage with the transmission in gear with potentially disastrous effects. In some installations, it will only check that the transmission is in park. They have only have neutral, which is sort of like park, but the transmission is able to freewheel. There is no parking pawl, which is the component in automatic transmissions that locks the transmission in place. This is easier to deal with than the issue of making sure the transmission is in neutral, but its still an additional hurdle that doesnt apply to vehicles with automatic transmissions. This is a switch that prevents the engine from starting until it is tripped by fully engaging the clutch pedal, so its pretty easy to bypass. The interlock also prevents kids from accidentally rolling the vehicle into a building or traffic when left unsupervised. Even with the parking brake set, the vehicle could easily hit another vehicle under those circumstances. Without the parking brake set, the vehicle could roll into a building, a roadway, or even hit a pedestrian. Verify the transmission is in neutral. Verify that the parking brake is activated. In order to bypass the need for someone to actually depress the clutch pedal, the remote car starter has to be wired into the clutch interlock. In a similar process, the device can also be wired to the same parking brake switch that activates the parking brake light on your dash. If that switch isn't activated, the remote starter can be disabled entirely. Most of these socalled solutions were overly complicated and prone to failure, but modern remote car starters take advantage of a lot of years of trial and error. To accomplish this, the remote starter alters the way you shut your car down. It also has to be wired into the door

switches. <http://alliedteamworkconstruction.com/nbloom/fckuploads/diseqc-switch-manual.xml>

- **can you install remote starter manual transmission, can you install remote start on manual transmission, can you put remote start on a manual transmission, how to install remote start manual transmission, can i install a remote starter on a manual transmission, can you put a remote start on a manual transmission vehicle, 1.0, can you install remote starter manual transmission, can you install remote start on manual transmission, can you put remote start on a manual transmission, how to install remote start manual transmission, can i install a remote starter on a manual transmission, can you put a remote start on a manual transmission vehicle.**

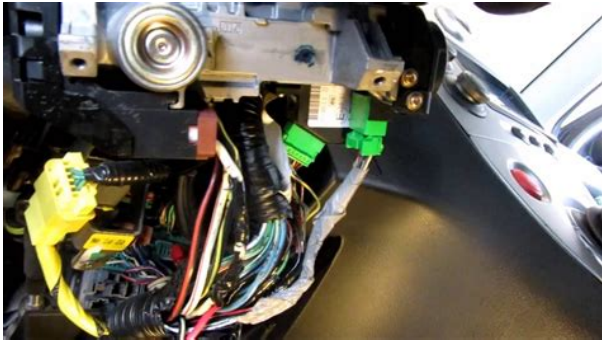

There's no need for a complicated position sensor on the transmission linkage since there's no way to arm the remote starter without the transmission being in neutral. That essentially means that if anyone opens the door, and potentially shifts the transmission into gear, the remote car starter will be deactivated. That obviously won't cut it for a remote starter, but a knowledgeable technician will typically be able to alter the wiring to make it work. The short answer is Sure you can. But I am confident that you want more information than that! Read on. Back in the day, there were all kinds of methods to do a remote start in a standard shift. One manufacturer had little lights that you had to line up to ensure that the shifter was in the neutral position. What a joke that was. There was nothing out there that appeared to be both safe and reliable. So what changed our minds. A couple of years ago, our remote starter vendor, Compustar, came up with a very easy to use, reliable and safe method. That method has been improved upon and today, is very foolproof. First of all, you must have the emergency brake on. Second, the vehicle must be in neutral. If either one of these conditions does not exist during the remote start sequence, the result could be deadly. The car could buck forward and roll down a hill. Not good. Most vehicles have a wire attached to the emergency brake. If the brake is not engaged, the remote car starter realizes this and will not let the vehicle start. But what about the shifter First of all, when you are ready to get out of your car, you need to engage the emergency brake. You do this before you shut off the car. This is a sign to the remote car starter to keep the car running even after you turn off the key. After that, you press the start button on your remote car starter remote. Next you actually turn off the key and the car stays running. Now you make sure that the car is in neutral and get out of the car. [http://fire-matic.com/testingsites/advantage\\_aviation/assets/media/disgaea-2-manual.xml](http://fire-matic.com/testingsites/advantage_aviation/assets/media/disgaea-2-manual.xml)



When you close the door, the car shuts off. Why go through all of that. If the car is still running when you get out of the car, obviously it had to be in neutral. As long as no one has opened the door since you exited, the car will start. If the door was opened, the car will not start. This is a safety feature to ensure that no one has gotten in the vehicle and put it back in gear. Opening the door interrupts the specific series of events that needs to happen in order to start the car remotely. Once the door is opened, you need to repeat the process outlined above before remote car starting. Please stop in

anytime for a free estimate on a remote car starter for your standard shift vehicle. It is filled with over 25 pages of great advice to ensure that your buying experience is a great one! Can a remote car starter be installed in this vehicle Can this be installed on something that old First off im a 12 volt installer neways DEI makes a remote start for stick shift cars, and the other ways is to custom fab a ring around the stick shift and make sure it grounds out if in gear. Never owned anything else. The problem with this statement is that it may not rely on mechanical parts that yes, have a chance to fail. However it relays on an electronic system that eventually WILL fail. There's no way around that. Nothing electronic in this world is made to last. My point had nothing to do with muscle cars. Just that the current solution offered by Compustar is far far superior to the old school mechanical devices. I stand behind my statement. Whereas if the mechanical version grounding ring fails, the car would start since it wouldn't think it's in gear. Therefore, if there is an air leak, the brakes come on. Some famous engineer. I don't fully understand if Ford MyKey is useful at all, need to look into this issue more. The car tells me when to shift, so they already have a sensor.

It just seems somewhat redundant and a slight personal inconvenience to signal the remote starter with the parking break, then fumble with the transponder on your keychain to press the button and signal it again, and then remove your keys. Again I may be overlooking some safety aspect here redundancy is the key to safety of course, but it seems to me it would be just as safe if you used the parking brake to signal the remote starter to enable instead of a combination of the parking brake and the button push. And your parking brake should only be on when you're parked, which is why it would be a good indicator to enable the remote start, unless of course you want to manually enable it at specific times only. My point was how I can't see that this adds to the safety, it just seems to me like it allows you to choose whether or not your remote start is enabled when you exit the car. If it was in gear when they got out of the car while it was running, the car would have been rolling already. I was wondering if i could put an automatic car starter in it. Please help. Perhaps they took other precautions. This would never be the way that we would do it. And I'm a little embarrassed that someone in my industry would do this. Gives us all a bit of a black eye. What you need to do is go back to that shop and ask them to explain exactly how this vehicle is safe and how ALL of the required safety functions perform properly. Make them show you. If they cannot, I would politely ask for them to take it out and refund all of your money. Injuring someone because of this potentially bad install would be horrible to live with. With my car it has to be in reverse to remove the key so netural and e brake isnt an option. I figure the answer to my. Is this a defect in your switch, or the way it was from factory I too have that exact vehicle. I've been told you cant put a remote start in our car. With having to leave the key in the ignition only invites a thief to take it.

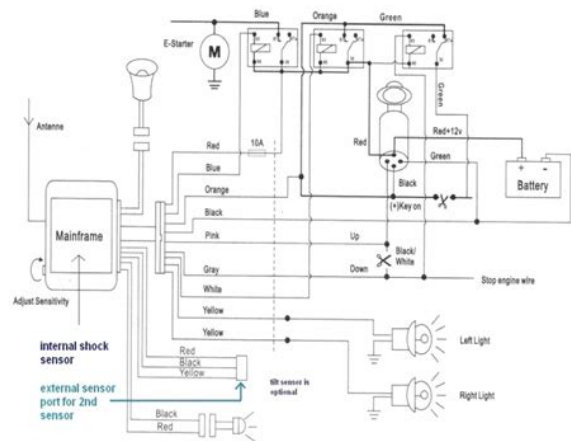

There should be an electronic switch to allow the key to be released when the shifter is in reverse. We should be able to recreate that scenario once the system has activated reservation mode by setting the Ebrake. It would require some additional diagnostic and wiring, but it can be done. Stop in anytime with the vehicle and we can provide you with a firm price quote. Was thinking about an auto starter. Worried about hassle and safety. Would it work in this car. Is it worth it We feel that they are very safe however we would always tell you not to do anything unless you are 100% comfortable with it. Stop in with the vehicle when you have a chance and we can go over the unit in detail and answer any questions. Can you use the remote start in conjunction with a turbo timer. I don't see how it can work but if it can, I'd definitely be interested in it. I'm not sure if this would be possible, but we would be happy to look into it. Stop in with your vehicle and let us take a look at exactly how your turbo timer operates and perhaps we can make this work. Thanks for the great comment and question. Stop in with the vehicle at your convenience and we will look it over and quote you a price. Thanks for checking out our site! I would look for a quality installer in your area and have them look over your vehicle. My company Cotronix designed and sold the ComfyCar back in the 80's. Not saying that it has not and cannot work. It is not something that we would be comfortable putting our name on. If we cannot feel comfortable that the vehicle will start all the time, we will not take the job. What model of a command start would you recommend. He started out in the 80's at DesignTech. It has problems starting sometimes does the remote start know to try to restart it if doesn't start the first few cranks Well, I'll have to think of another Christmas gift. Lol. 0.0 We have done hundreds of Manual Trans installs and have not had any issues.

<http://www.compass-it.com/images/brother-industrial-sewing-machine-repair-manual.pdf>

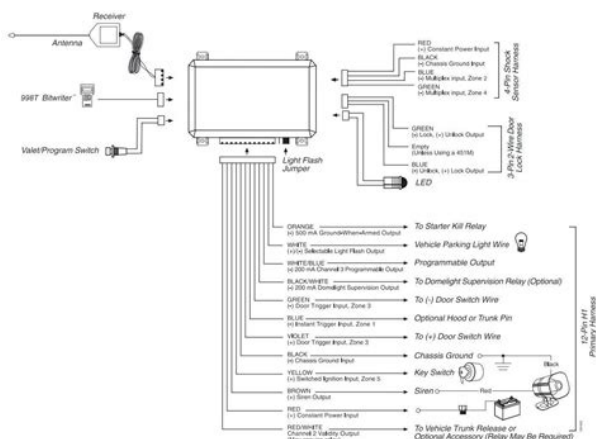

The install took all day but it has worked as advertised since I put it in. Do you guys sell anything antenna or otherwise that I could incorporate with this install that would give me better range. Perhaps a remote with an antenna I would contact the manufacturer and see if they can give you any advice. It would be our opinion that you should take this back to your installer and explain what happened. They should be able to assess your problem. Obviously, I cannot make it to your shop for installation and I cannot find a local shop who is willing to do an install. Can you provide instructions to safely install remote start. Would that affect the shutdown and subsequent restart of the engine. Thank you for having a safe way to install remote start on standard transmission cars. Now I will not settle for anything less than your setup. Unfortunately we do not offer installation advice, particularly for remote car starters. There is way too much liability involved. What you really need to do is to find a quality shop that does excellent work. You may gladly put them in touch with us if they are unfamiliar with the process that we use. Currently, we recommend Compustar remote starters and you can use their dealer locator at The part would detect any motion with the vehicle. We require this on any "convertible" vehicles with standard trans that we would do a remote starter

install on. You say the system shuts off if the door is opened so does it shut off even when I'm getting in the car after I've remote started it When remote starting the vehicle, this does not come into play and the vehicle will stay running. You get in, put the key in the ignition and turn it to the "on" position. Tap the brake and drive away. It's that simple. We have been selling Compustar for several years and they are a top notch company. Go to and use their dealer locator to find some dealers in your area.

<http://completedetailspainting.com/images/brother-hs-70a-operational-manual-pdf.pdf>

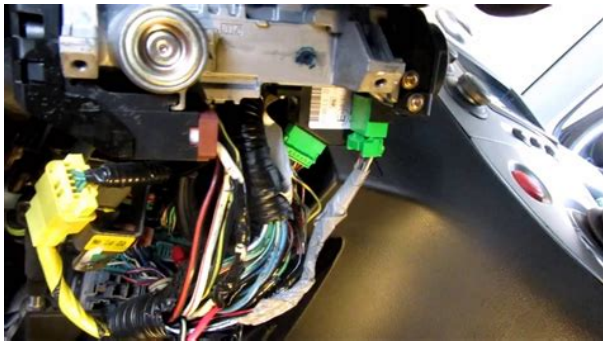

I recently have had problems with it starting and everything I have read say that this car has a manufacture glitch that some antitheft gell in the ignition freezes and it wont start in the cold. Some people say that there is no way to fix it and others say that installing a remote start will bypass that antitheft issue and allow the car to start everytime. But it is a manual and I dont think my E break works well because the car always slides on a hill even when it is in 1st gear. Do you think a remote start would fix it and is a remote start even possible Thanks! I do not agree that a remote starter should be used to bypass an existing problem. If there is an underlying problem, that should be fixed before installing a remote car starter. I have a Toyota Corolla AE86 GTS with 5 speed manual transmission. I wouldn't see any reason why it wouldn't work on yours. Would a remote start work for this truck since I am purchasing a system by viper which is the 5701v security system with remote start I can tell you that we can install a Compustar in your vehicle. Just make sure that you go to a specialist retailer to purchase and install your starter. We have had a great deal of success with them. However, I will not always want to use the remote start when I activate the parking brake, and I usually put the car in 1st when using the parking brake. Is there any way to install an alternate activation method such as a button so I could use the parking brake in conjunction with 1st gear when I park Engaging the parking break is one of the things that you NEED to do in order to use the remote starter. I hope that makes sense. If I am understanding your question, you do not need a special switch. Does it reset the system at that point or is it just the driver side door My honda accord is a 2009 and stick shift. Is there a possibility to use that one Compared to the premium model and the sister car Scion FRS, the subaru brz limited has both keyless entry and push to start.

Is it possible, and what are the risks to get a remote start for a push to start ignition. This may be my deciding factor which model to choose, so I appreciate your comments. That said, we sell the Compustar brand at our store and have nothing but excellent things to say about the company. You should find a Compustar dealer in your area and have them show you some models. When I bought the car, he showed me how to use the Command Start and I saw that it worked. Now, unfortunately, no matter what I try, I cannot take the keys out of the ignition and leave the engine running as you explained and as the previous owner demonstrated. I've tried leaving it in neutral and with the Ebrake on. Nothing works. Can you please let me know how to accomplish this It is a serious problem. You should discontinue using the remote starter entirely until you can get the vehicle to a

Viper dealer for assistance. In my car, the alarm goes off if there is an attempt to start the car while the alarm is armed. The alarm arms automatically when the doors are locked. Is it possible to install a remote start without setting off the alarm when it is used We would need to look over your vehicle here at our store to get more specific however. Even in neutral I have to push the clutch in to start it. And with all the security's systems BMWs have is its still possible to install a remote start My issue with mine is if i go into my trunk for any reason after i have shut off my car, my auto start will not work. Is this a safety feature aswell as the doors being open after the fact.I have had many discussions with installers on this subject. The one issue always is what if we have taken the doors off. I don't really need remote start in this situation however how do I turn the car off if I can't shut the door As you said, it needs to see the opening and closing of the door in order to get into reservation mode.

<http://juliesteban.com/wp-content/plugins/formcraft/file-upload/server/content/files/162706f0f137d1--boss-sx-700-studio-effects-processor-manual.pdf>

Without that happening it would not be able to be put into reservation mode, thus not allowing the remote starter to function. How difficult is it to take off the doors when the sensor wire for the starter in place. Is this something I can do, or would I have to bring it into the shop Unfortunately, we do not offer any installation assistance on the site. We simply are not staffed for this. If you are local to our store, you could bring the vehicle to us and we can provide you with an installation consultation. There is a reasonable fee that we charge for this service. I wish you luck with your project. But, I have a 2010 Genesis Coupe that unfortunately operates in the winter. It has a push button start. You mention having to turn a key to have this method work, would turning off the ignition with the push button have the same effect, or no. If not, are there better options for my vehicle I would recommend finding a skilled installer. Stop in with the vehicle and let us take a look! It is a manual transmission.It has a Clifford Responder LC3 570.4x alarm and remote start system. When I try to remote start the Jeep, I get a "remote start error" statement on the remote control. It says if I get this to refer to the online manual. There is not an online manual for this model on the Clifford website. I also followed the directions in your video about the reservation mode. Any suggestions I would definitely consult with an authorized Clifford dealer or contact the manufacturer. Since it is a manual transmission, you do not want to mess around with maybes or assumptions. Can you put a remote start in this type of vehicle Please stop in with it and let us have a look. We can go over all of the options and at that point figure out what it is going to cost. However, the clutch switch was disengaged to be off and was bypassed when the starter was installed. This means I can start my car no clutch while I'm in it, from both 1st gear shoots forward and from neutral.

Is this normal Couldn't some prankster reach through an open window and put the car in gear For folks that do not want to leave anything to chance we offer a sensor that detects movement. If it does see movement, it immediately shuts down the vehicle. Please stop in with your Ranger and let us show you what options are available. Feel free to stop in anytime during normal business hours! Can you tackle these yet, Mitch While there are solutions available, we have found that, in general, they do not provide a good user experience. Please stop in with the vehicle at your convenience. Mercedes vehicles are always something that we like to take a look at before quoting. And yes, a skilled installer can install a remote start in your vehicle. Good luck with your search. BTW, You've got mail. That will do a GOOD JOB. Thank you!!! I'm not sure if they offer Manual Transmission installs, but that is where I would start my search in your market.Can a remote starter be installed Or is it do able The Mazda dealer told me the same and said it wasn't possible. They installed a 2way viper autostart in my vehicle. The engine will remain running. 3 Get out of the vehicle, use the lock button on the Viper remote to lock the doors. When the door is opened, the engine will turn off. So with the pushbutton start, you will have to restart your engine once you're in the car. That way they

turn on when I autostart, and I get into a roastytoasty vehicle, that has no frost on the rear window and mirrors The place else may just anyone get that kind of information in such an ideal manner of writing. I have a presentation subsequent week, and I am at the look for such information. Problem is everythings wired up great and works. Only problem im having is that when i start my car i push on the clutch and the starter engages. Not sure why but all my connections are good. Any ideas where the problem could be Thanks! It is an Australian, or U.K. version. I live in Australia.

Do you have a kit for my Australian vehicle Thanks, Steve. I do not have to use key and turn like older vehicles just have to have the advanced key within range. Can this be used if I have this. And also how does it work for instance if the trunk is opened will reservation mode be turned off. Or does the driver door have to be left open and then the last one closed. Because in all seriousness somebody could climb in from the trunk or any other door and put it in a different gear or change one of the other requirements. Would I be able to have this installed. Also would I have to put my vehicle in "Reservation Mode" after each park, or would I have to do it once and it be saved to the vehicle and remember the set "Reservation Mode" Thx for your reply Truck turns off when key is turned. Anything I can do or does it need the installers service. Thanks. Andy Im curious if thsi would work on my car and I was also curious if i could install it myself, how much it cost, and how much it cast. The first thing anybody learns when driving stick is to keep the car in 1st gear when you park in addition to activating the emergency brake. This is a safety feature. This goes against what you say to do in your video so I'm a bit confused I'm in the Dallas, TX area. Do you have any suggestions on where I could get this done in my area Keeping in mind that in the cold temps, it takes bit of turnover to start. And would the remote start be able to heat the glow plugs, like turning the key does Thanks I laughed quite a bit. Remote starters for a manual transmissions is a simple case of people wanting to have their cake and eat it too. If you want a remote start, get an automatic. Otherwise stop being lazy and go start your car.

Would I still be able to get a remote start feature You can use the best adsense alternative for any type of website they approve all websites, for more details simply search in google boorfe's tips monetize your website I know it's a little more work but much less hassle for the client in the long run. Mine is broken and I have looked everywhere to find a replacement but don't know what the remote starter is in my truck as I bought it used. The auto version has remote start preinstalled in the Ford Pass Connect App. Is it possible to enable remote start for a manual in the app. Many thanks, Simon Thanks for your inquiry. I appreciate you finding the time and energy to put this article together. I once again find myself spending a significant amount of time both reading and posting comments. Learn how your comment data is processed. Search our site with any combination of CATEGORIES, TAGS, or KEYWORDS We ask that you only request an estimate if you are able and willing to bring your vehicle to our facility here in Pennsylvania for installation. The site may not work properly if you dont update your browser. If you do not update your browser, we suggest you visit old reddit. Press J to jump to the feed. Press question mark to learn the rest of the keyboard shortcuts Log in sign up User account menu 3 Can you install a remote start key on a manual transmission car Can a remote start system be installed and work even if the car is a manual, and if so does it need to be a specific system or could I pull into the nearest BestBuy and pick up any system that I like. Thanks in advance! Edit Thanks everyone. The issue is that to do so, you need to bypass the clutch safety switch, which is rather easy to do. But few installers will do it due to liability. Imagine you hit the remote start and the car is parked in gear.

This is why any manual transmission car that comes into stock I am a dealer with a remote start gets that removed and we will NOT install one in a manual transmission car for anyone. Wouldnt the car stall right after starting. There's an old video of some mechanic pressing the remote start button on a customer's RSX not knowing the car was in gear, and it just started and took off with no driver. The car would stall before getting past 5mph. Did he lay a brick on the accelerator as well. I had a



third party Viper remote start installed in my old car, 06 Legacy GT with a 5MT. This ensures that your car will NOT start in gear and will NOT fuck up your starter motor. Its not any more hazardous than an auto its maybe slightly less convenient because you need to park on a flat surface. I had no issue finding an installer to do mine. Had the same system in my E36 M3. A cool side effect is after you prime it you can take the key out and leave the car running, unlocked. If anyone gets inside and touches a pedal without the key being reinserted it shuts off. I used to leave my car running during quick stops constantly. Leave it neutral or a switch can be installed the prevents starting in gear. You can, but its considerably more hazardous than doing so in an auto. Honda themselves dont offer remote start for manual transmission vehicles because of this. That would require you to park in neutral all the time, and bypass the clutch switch. And if you forget to leave the car in neutral youd fuck your starter real quick. Car will start. What you will fuck up is a lot of body work. Is this just in newer cars. My 80s manual will lurch and die if I accidentally start it in gear. Am I missing something. I think thats the important part. All rights reserved Back to top. Remote starters safely start a vehicle's engine by simulating the presence of the vehicle's key within the vehicle.

Most importantly, remote starters are safe, as the vehicle cannot be put into the gear without the presence of the actual key. There are a couple explanations for this perception However, stickshift drivers are not out of luck. These solutions center around the company's CM7Series control modules, which address each of the concerns mentioned above. This connection simulates the electronic signal produced by the clutch pedal, normally a ground signal sent to the vehicle's ignition system. This allows the engine to be remotestarted even without the driver's foot on the clutch. The purpose of reservation mode is to confirm that the vehicle is safe to remotestart. Reservation mode can be activated by doing all of the following The engine will continue to run, confirming that reservation mode is in the process of being activated; The reason for this is that someonefor example, a childreenters a vehicle after it has been put into reservation mode, there is the slight chance that the parking brake may be disengaged. Thus, Compustar systems will only remotestart the engine if it is 100percent safe. This sensor has a builtin accelerometer that will immediately shut off your remote starter if it detects forward movement without the presence of the actual key inside of the vehicle. If the brake pedal is pressed to put the vehicle into gear, the system will detect whether or not the key is present inside of the vehicle. If not, the engine will immediately shut off. This is possible because of the additional safety features that Firstech has built into the company's CM7Series control modules.If you want to learn more or withdraw your consent to all or some of the cookies, please refer to the cookie policy. You agree to the use of cookies by closing or dismissing this banner, by scrolling this page, by clicking a link or by continuing to browse otherwise. If you want to learn more or withdraw your consent to all or some of the cookies, please refer to the cookie policy.

Click to see full answer Also know, can you get remote start on a stick shift. There are several issues with installing a remote starter in stick shift. First of all, you must have the emergency brake on. So in order to make a remote starter function safely, it needs to be able to monitor both the E brake and the shifter. Secondly, is Remote Start bad for your car. Some people say they dont want a remote starter because it can damage their vehicle. The fact is that a high quality, properly installed system will not cause any damage to your vehicle. Regarding this, will Best Buy install remote start manual transmission Answers. Best answer We can generally install remote starts on manual transmission vehicles, but it may vary from model to model, and additional parts may be needed. Why does tapping a starter make it work. This works because the brushes wear out which results in an inadequate electrical contact. By gently tapping on the back of the starter with the hammer, the brushes are knocked back into place so they can make contact one more time. Its not that they wont work — most places just wont do it as its too much of a liability if the car is parked in gear and remote started, its going to lunge forward. If a remote starter was available for your cars model, trim, and transmission when the car was new, you should be able to have one added to your car,

Ibbotson says. There are a couple very important notes you should keep in mind here, though That usually does not include installation. If it has a manual transmission and you have it parked on a hill, you can roll it down hill, push in the clutch, place the transmission in 2 nd gear, get it up to about 15 mph, turn the ignition on and release the clutch slowly so as not to lock up the tires. If it has a remote start button with a semicircle with an arrow at the end you should have remote start.

<https://labroclub.ru/blog/4-door-jeep-wrangler-manual-sale>